

Série Máxi 4-cilindros

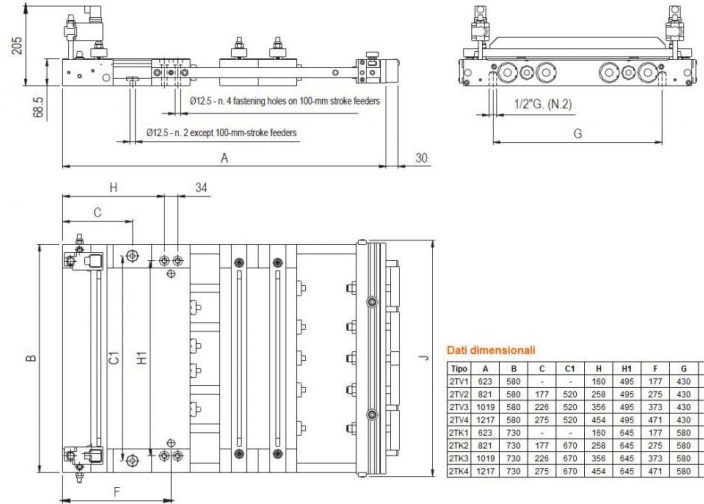

Diagramma cicli/minuto

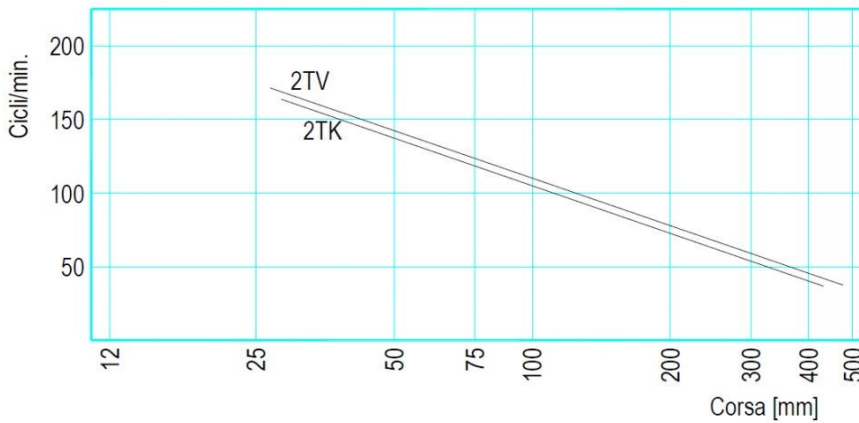

Modelos	Largura máx. chapa [mm]	Curso máx. [mm]	Espessura máx. [mm]	Ciclos min.	Pressão no mordente fixo [kg]	Pressão no mordente móvel [kg]	Força de tração [kg]	Consumo de ar [litros/min.]	Peso [kg]
2TV1	460	100	3.5	110	280	1208	430	576	101
2TV2	460	200	3.0	85	280	1208	430	890	112
2TV3	460	300	2.5	65	280	1208	430	1020	123
2TV4	460	400	2.0	40	280	1208	430	838	134
2TK1	610	100	3.0	105	280	1208	430	550	116
2TK2	610	200	2.5	80	280	1208	430	838	126
2TK3	610	300	2.0	60	280	1208	430	943	139
2TK4	610	400	1.5	35	280	1208	430	734	154